



IOPAK 1.5M LONG CONVEYOR WITH HOPPER

STOCK ITEM: 18278

SPECIFICATIONS

Conveyor Speed:

10 m/min

Conveyor Length:

1,500 mm

Conveyor Width:

350 mm

Hopper Infeed Height:

1,050 mm

Belt Type:

Food-Grade PVC

Motor:

0.37kW

Power Supply:

3-Phase, 415V, 50Hz*

The above specifications may change without prior notice.

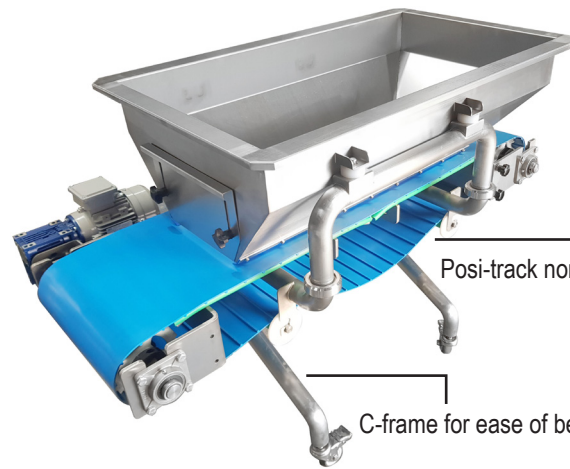

Posi-track non slip belt eliminates the need to track belt.
High quality food grade belt, sealed both sides.

C-frame for ease of belt removal.

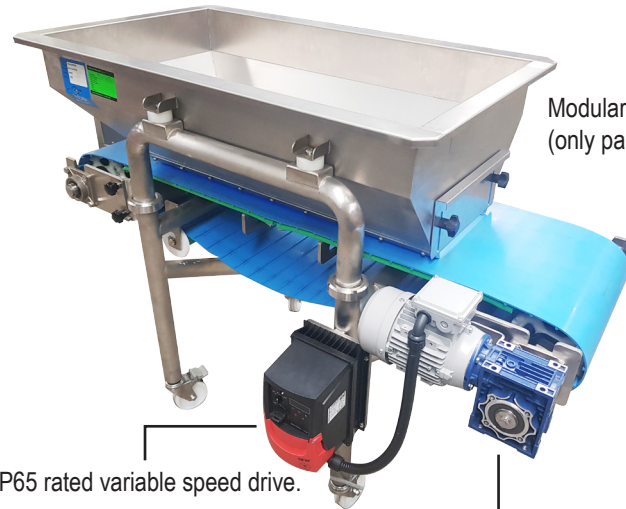

IP65 rated variable speed drive.

Washdown optional motor available.

Modular design allows maximum length to 5mtrs
(only part changes required, no welding needed).

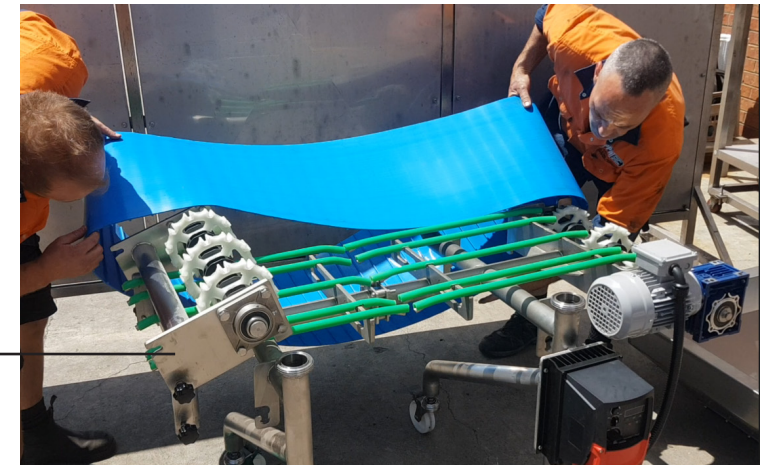

Flip up for quick release of belt.



PROCESSING & PACKAGING EQUIPMENT CUSTOM DESIGN SERVICES

For more information on this machines call sales: +61 3 9791 7011 or any others visit: www.iopak.com



IOPAK 1.5M LONG CONVEYOR WITH HOPPER

STOCK ITEM: 18278

“
We can
customise
to your needs
”

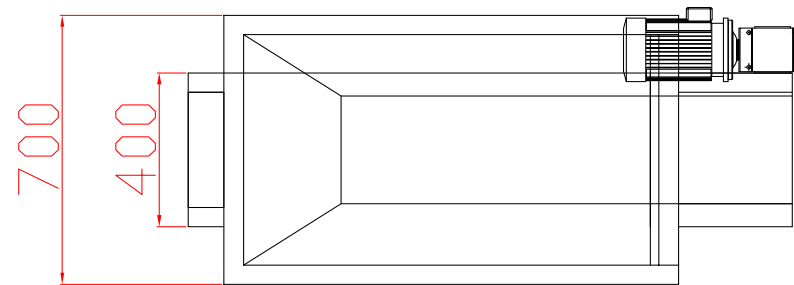
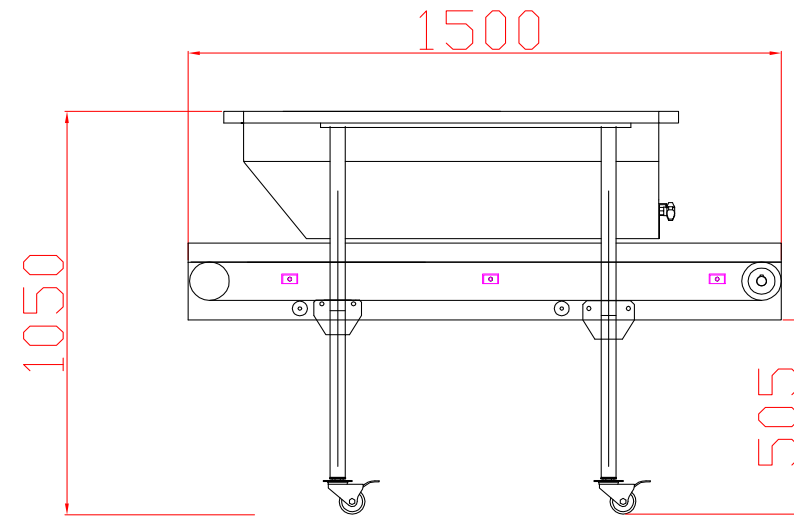

PPN MACHINERY
PROPRIETARY
LIMITED
THE COMPLETE PACKAGE

PROCESSING & PACKAGING EQUIPMENT CUSTOM DESIGN SERVICES

For more information on this machines call sales: +61 3 9791 7011 or any others visit: www.iopak.com