



IOPAK WASHDOWN STAINLESS STEEL BUCKET ELEVATOR WITH VIBRATORY FEEDER

STOCK ITEM: 20528

SPECIFICATIONS

Discharge Height: 3,800 mm

Feed Entry Height: 907 mm above Floor

Horizontal Discharge Section: 1,400 mm

Bucket Volume: 1.8 L

Material Constructions: SUS304

Motor: SITI 0.75kW

APPLICATION

Potato slices and chips, salads, raisins, oatmeal, candy, peanuts, walnut kernels, apricot kernels, popped food, sugar, jelly, frozen dumplings, meatballs, dry powders, salt etc.

* The above specifications may change without prior notice.



PPN MACHINERY
PROPRIETARY
LIMITED
THE COMPLETE PACKAGE

PROCESSING & PACKAGING EQUIPMENT CUSTOM DESIGN SERVICES

For more information on this machines call sales: +61 3 9791 7011 or any others visit: www.iopak.com



IOPAK WASHDOWN STAINLESS STEEL BUCKET ELEVATOR WITH VIBRATORY FEEDER

STOCK ITEM: 20528

“
We can
customise
to your needs
”

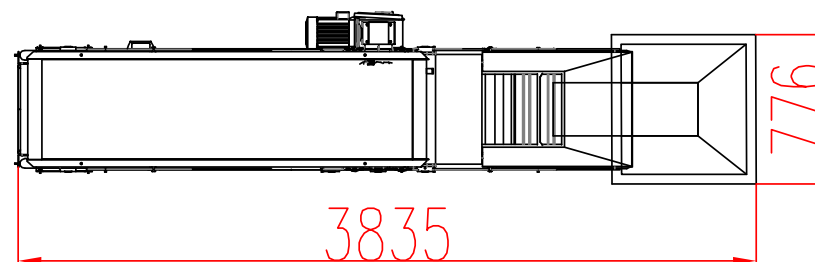
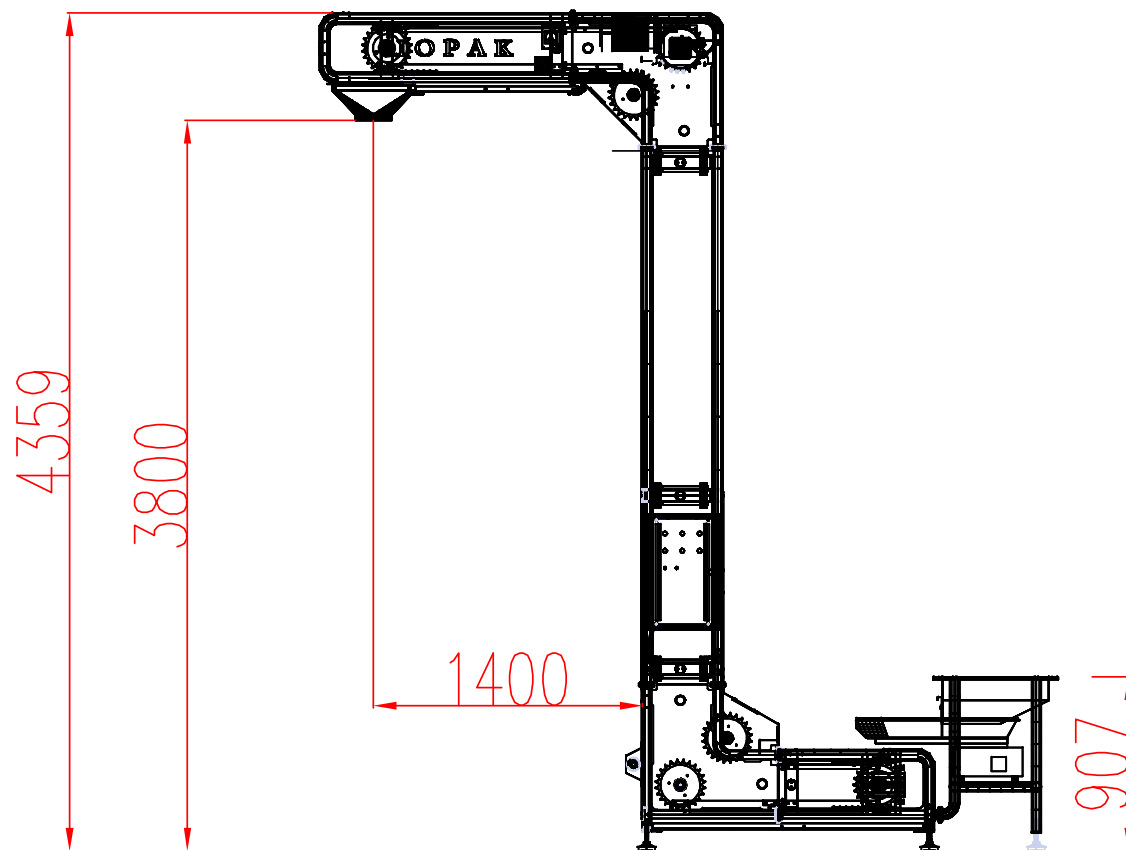

PROCESSING & PACKAGING EQUIPMENT CUSTOM DESIGN SERVICES

For more information on this machines call sales: +61 3 9791 7011 or any others visit: www.iopak.com