



# IOPAK CONTINUOUS HIGH SPEED MOTION VFFS

STOCK ITEM: 20533G

Continuous motion for high productivity. Maintenance free servo technology ensures reliable production. PLC controls enable precise machine movements for smooth production and good quality bags. Intuitive HMI allows easy operation and short training time. Open machine concept for easy access and maintenance. Compact machine design for good ergonomics, product conserving filling and space saving. Can supply suitable filling device according to your application.

## Bag styles:

Pillow, gusseted,  
Block-bottom



## Ideal for:

Instant coffee, laundry and dish washing powders, sugar and free flowing powders and granules.

## TECHNICAL SPECIFICATIONS MODEL YS-BS-2520-CP-A

### Bag Type:

Pillow bag, gusseted bag

### Standard capacity:

10-150 bags/min

### Pillow Bag Size:

W: 60-250mm

L: 60-400mm

### Max Size:

4.5L

### Gusseted Bag Size:

W: 50-220mm

D: 35-110mm

L: 60-400mm

**Width:** 2 times side depth

### Packaging Material:

Opp, Al, Pe, Pet, Vmpet, etc.

### Film Parameter:

Diameter:  $\leq 600$ mm Core: 76mm

### Total Power:

5KW

### Air Pressure:

$\geq 0.5$ MPa

### Air Consumption:

HS closure,  
0.32NL/Cycle

### Outer Dimensions approx:

1800\*1270\*1615mm

### Weight approx:

680kg

### Power Supply:

3N-PN-50Hz 380V/220V

(3P 5 wires)



PROCESSING & PACKAGING EQUIPMENT CUSTOM DESIGN SERVICES

For more information on this machines call sales: +61 3 9791 7011 or any others visit: [www.iopak.com](http://www.iopak.com)



# IOPAK CONTINUOUS HIGH SPEED MOTION VFFS

STOCK ITEM: 20533G

## Ideal for:

Instant coffee, laundry and dish washing powders, sugar and free flowing powders and granules.

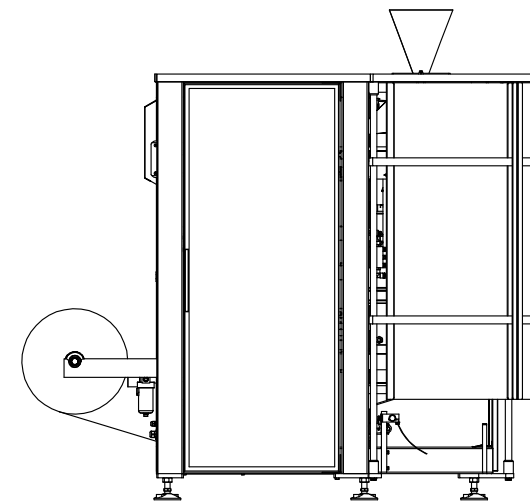
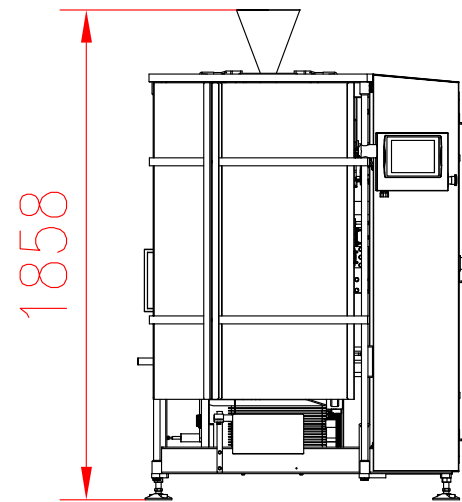

1954

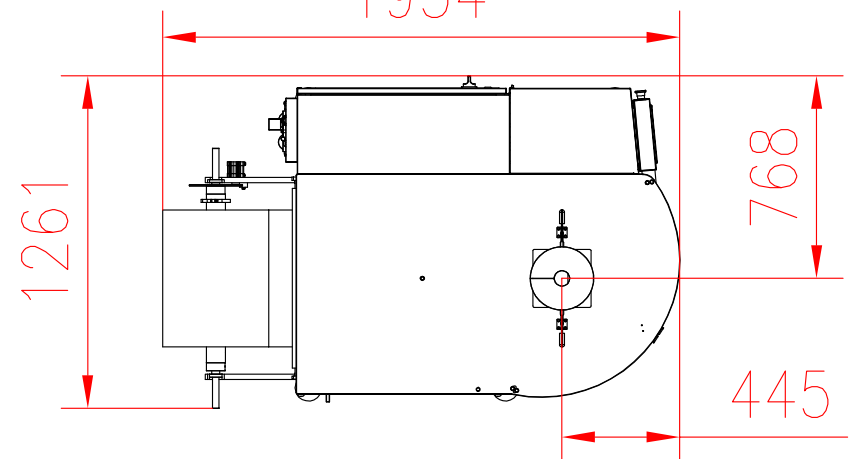

PROCESSING & PACKAGING EQUIPMENT CUSTOM DESIGN SERVICES

For more information on this machines call sales: +61 3 9791 7011 or any others visit: [www.iopak.com](http://www.iopak.com)