

Paddle Mixer MIX-2400

www.nadratowski.com

Total capacity [L]	2400
Max filling [L]	1900
Installed Power [kW]	22
Loader option	PZ-2/250 or PW-2/1000
Column Loader power [kW]	0,75
Standard control	PLC and HMI
Shaft rotation speed [rpm]	3 – 25 variable speed
Mixer net weight [kg]	2950
Unloading to bin DIN 9797	2 x 200 l
Opennig/closing lids	pneumatically

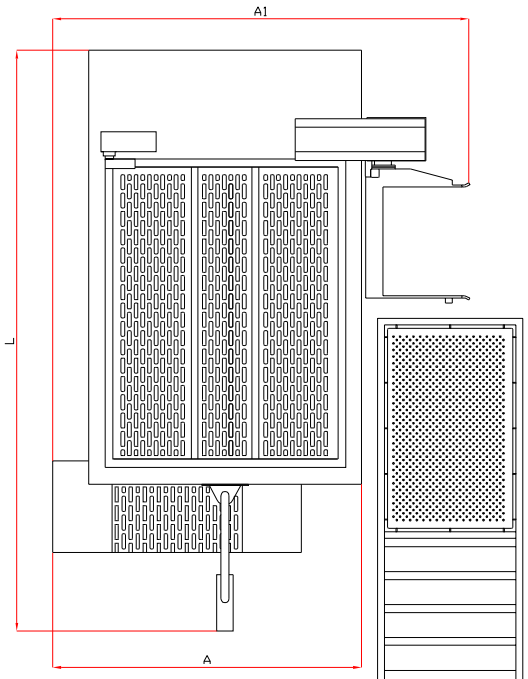
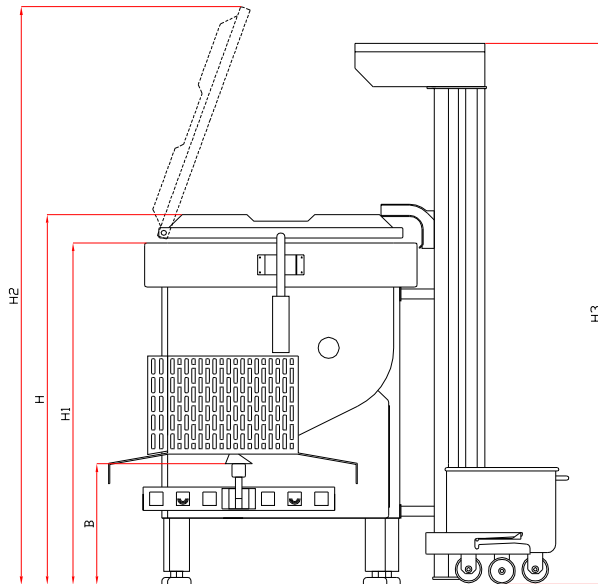

L [cm]	A [cm]	A1 [cm]	H [cm]	H1 [cm]	H2 [cm]	H3 [cm]	B [cm]
356	185	270	222	205	350	325	72±2

