

# Paddle Mixer MIX-650

Total capacity [L]	650
Max filling [L]	520
Installed Power [kW]	8,0
Loader option	PZ-2/250
Column Loader power [kW]	0,75
Standard control	button control panel
Shaft rotation speed [rpm]	18/36 II rotation speed & left/right rotation
Mixer net weight [kg]	980
Unloading to bin DIN 9797	200 l
Opennig/closing lids	pneumatically

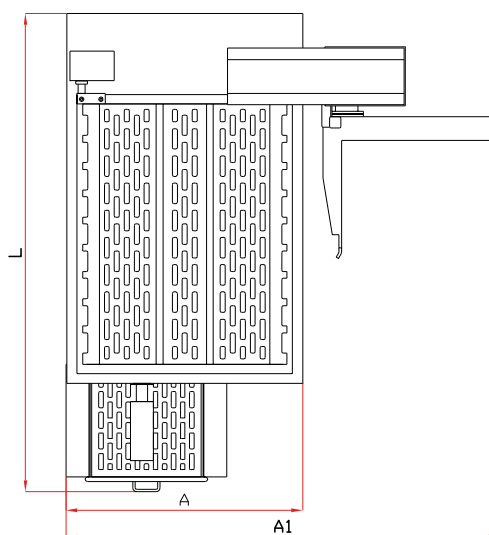
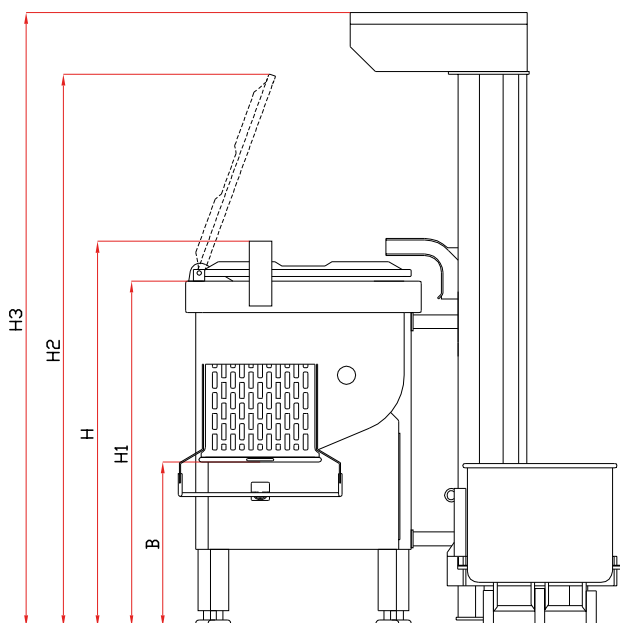

L [cm]	A [cm]	A1 [cm]	H [cm]	H1 [cm]	H2 [cm]	H3 [cm]	B [cm]
213	107	195	170	153	246	271	72±2