

# Paddle Mixer MIX-450

www.nadratowski.com

Total capacity [L]	450
Max filling [L]	360
Installed Power [kW]	4,5
Loader option	PZ-2/250
Column Loader power [kW]	0,75
Standard control	button control panel
Shaft rotation speed [rpm]	20/40 II rotation speed & left/right rotation
Mixer net weight [kg]	570
Unloading to bin DIN 9797	200 l
Openning/closing lids	manually

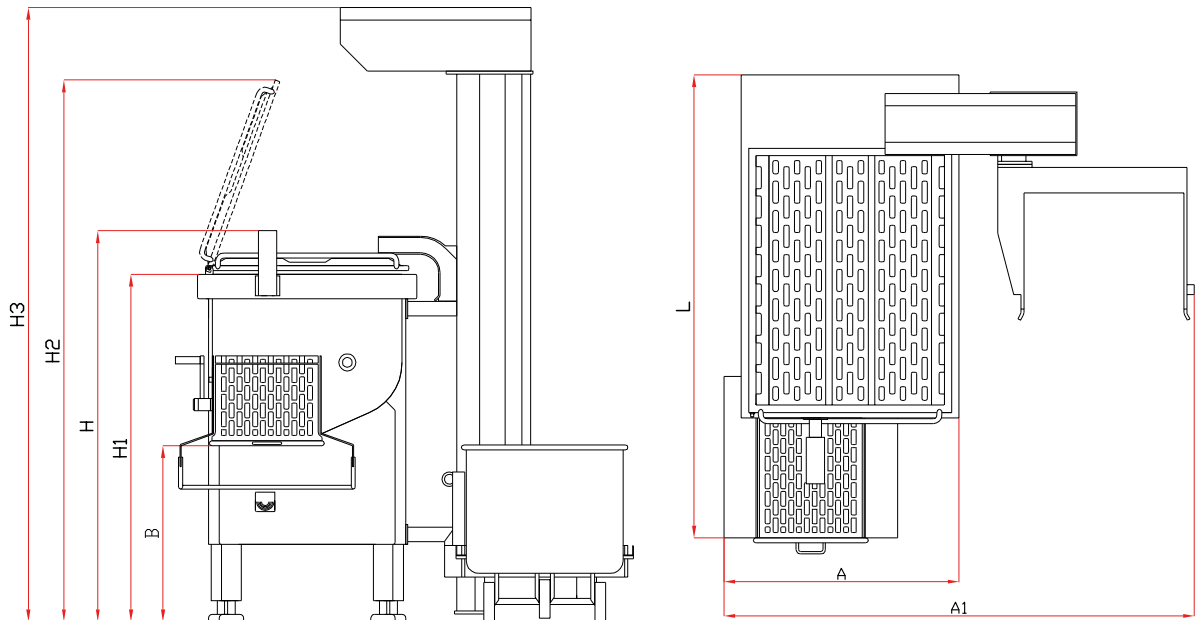

L [cm]	A [cm]	A1 [cm]	H [cm]	H1 [cm]	H2 [cm]	H3 [cm]	B [cm]
197	100	190	160	142	225	251	72±2

