

Vacuum Paddle Mixer MIX-180V

Total capacity [L]	180
Max filling [L]	120
Installed Power [kW]	3,0
Loader option	PZ-2/250
Vacuum pump	BUSCH 21m3/h
Column Loader power [kW]	0,75
Standard control	PLC and HMI
Shaft rotation speed [rpm]	6 - 60 variable speed
Required pressure [bar]	6
Mixer net weight [kg]	448
Unloading to bin DIN 9797	200 l [option 120 l]
Opennig/closing lids	pneumatically

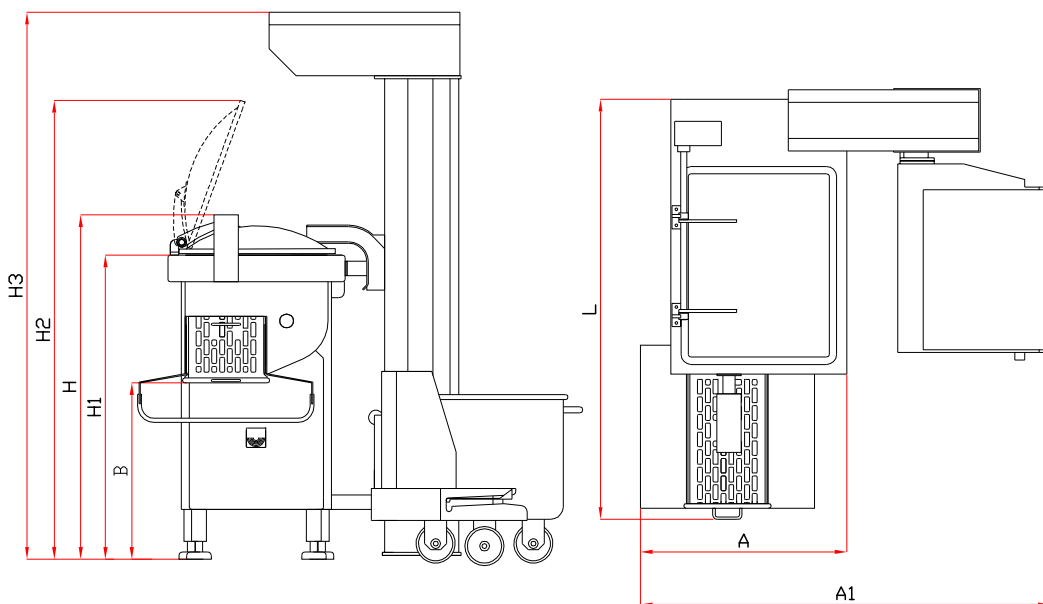

L [cm]	A [cm]	A1 [cm]	H [cm]	H1 [cm]	H2 [cm]	H3 [cm]	B [cm]
172	85	169	140	125	188	226	72±2

