

Paddle Mixer MIX-180

www.nadratowski.com

Total capacity [L]	180
Max filling [L]	135
Installed Power [kW]	2,4
Loader option	PZ-2/250
Column Loader power [kW]	0,75
Standard control	button control panel
Shaft rotation speed [rpm]	30/60 II rotation speed & left/right rotation
Mixer net weight [kg]	388
Unloading to bin DIN 9797	200 l [option 120 l]
Openning/closing lids	manually

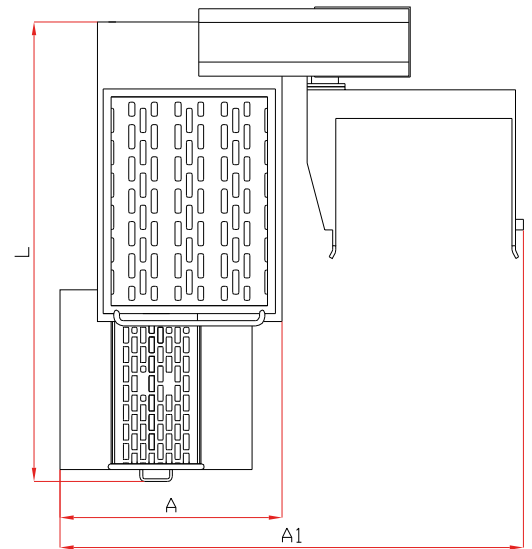
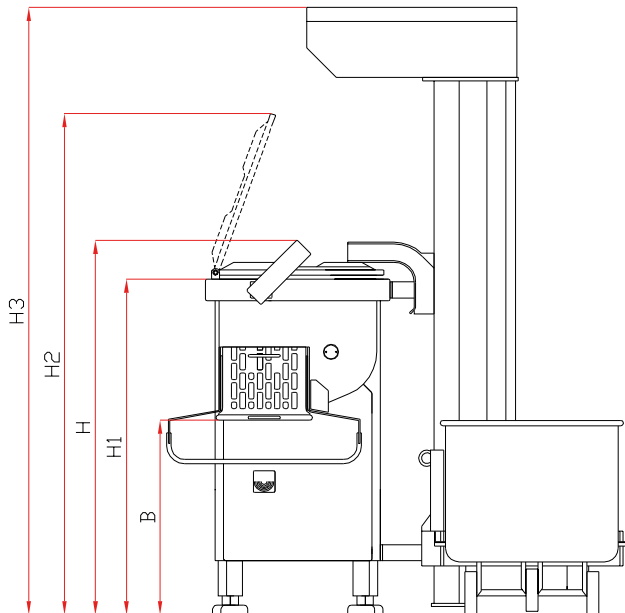

L [cm]	A [cm]	A1 [cm]	H [cm]	H1 [cm]	H2 [cm]	H3 [cm]	B [cm]
172	84	173	139	125	189	226	72±2

