

# IOPAK SEWING MACHINE

STOCK ITEM: 15711

## Specifications

- Speed: 2700pins/min
- Pin Distance: 7-11.5mm (standard 10mm)
- Max Sewing Material Thickness: 8mm
- Pin: DR-H30#26
- Thread Model: Dual-Line
- Thread Spec: 20s/6; 20s/9 fiber thread
- Lubricating Model: Total sealing (suggest Mobil Oil 32#)
- Thread Cut Model: Pneumatic
- Motor Model: Electromagnetism drive
- Power: 0.75KW
- Voltage: Three-Phase, 415V, 50Hz
- Frame: SUS304

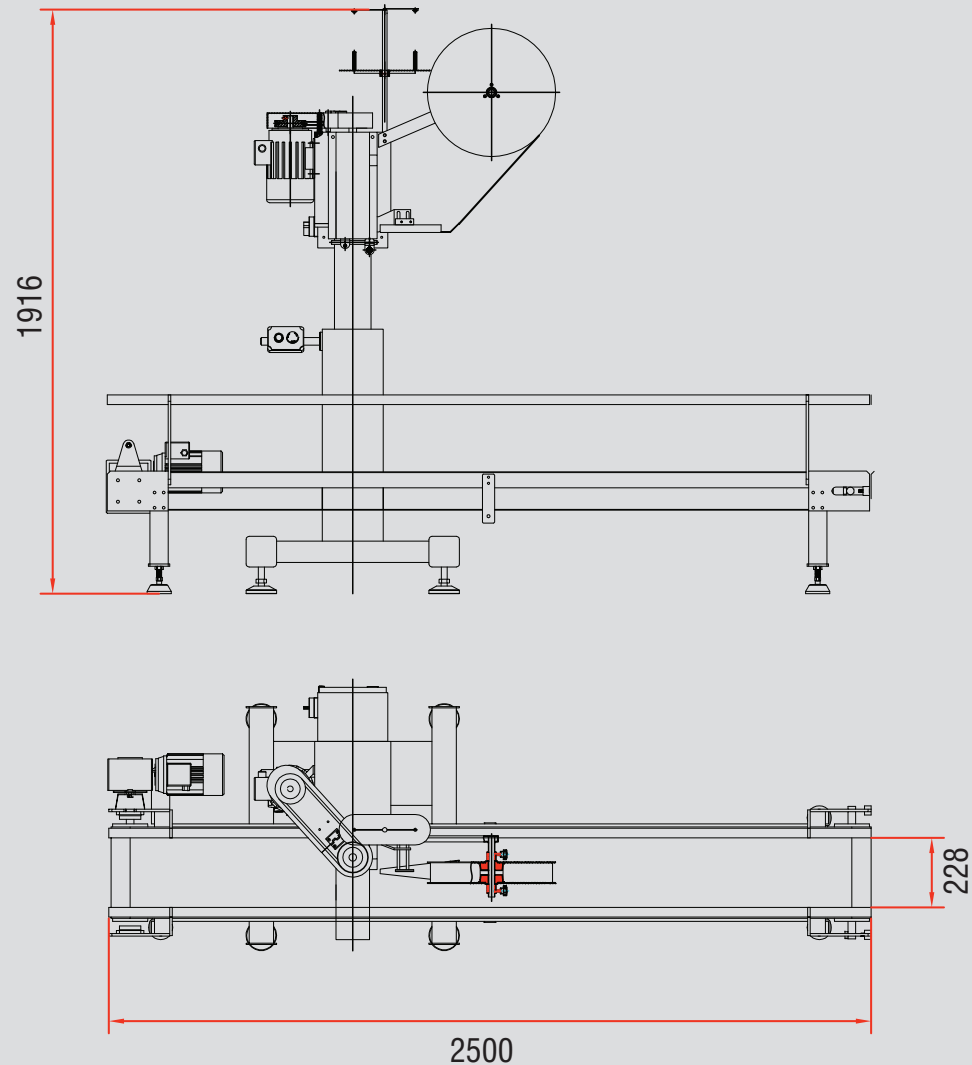

PROCESSING & PACKAGING EQUIPMENT CUSTOM DESIGN SERVICES  
For more information on this machines call sales: +61 3 9791 7011 or any others visit: [www.iopak.com](http://www.iopak.com)