

500L JACKETED COOKER KETTLE (CONTRA ROTATING) 316: 500 CRM



IOPAK has introduced a brand new fully stainless steel constructed jacketed cooker/kettle which can be used for cooking or cooling. The unit is fitted with a contra-rotating scrape surface mixing arm.

This kettle features 2 x half moon hinged lids for food hygiene. The interior of the tank has a dome base and is fitted with a 3" product outlet including an air actuated discharge valve.

A swept surface (Teflon tipped) stirrer is top and bottom bearing supported and direct driven by a 2.2kW, 29rpm, 415V AC, Three Phase gear motor. An additional contra - rotating centrally mounted agitator is fitted with a 0.75kW, 49 rpm gearmotor. A digital (- 20 to 150 deg C) temperature indicator indicates the temperature of the tank contents.

NEW &
INNOVATIVE
PRODUCTS



1. Dimple Plate
2. Teflon-Tipped Stirrer
3. Ball Valve Outlet

PPN MACHINERY
PROPRIETARY
LIMITED
THE COMPLETE PACKAGE

500L JACKETED COOKER KETTLE (CONTRA ROTATING) 316: 500 CRM

STOCK ITEM: 8531G

Specifications

- Design Pressure (WP) : 300 KPa
- Test Pressure (HTP) : 450 KPa
- Design Temperature (DT) :135 deg C (max 150 deg C)
- Code: AS1210 Class 3
- VWA: V0420425
- Internal Diameter 1100 mm
- Internal Depth 750mm
- Outer Diameter 1250mm
- Lid height above floor 1400mm
- Outlet Height above floor 560mm
- Overall Height 2162mm
- Jacket inlet & outlet ports 25mm diameter
- Material of Construction is 316 s/s (inner) 304 s/s (outer)
- Wall Thickness: 4mm inside wall, 2.0mm jacketed wall
- * Recommended Oil: TORA 220 or equivalent (if the gearbox is 7 years old or more, TORA 320 or equivalent)

NEW &
INNOVATIVE
PRODUCTS

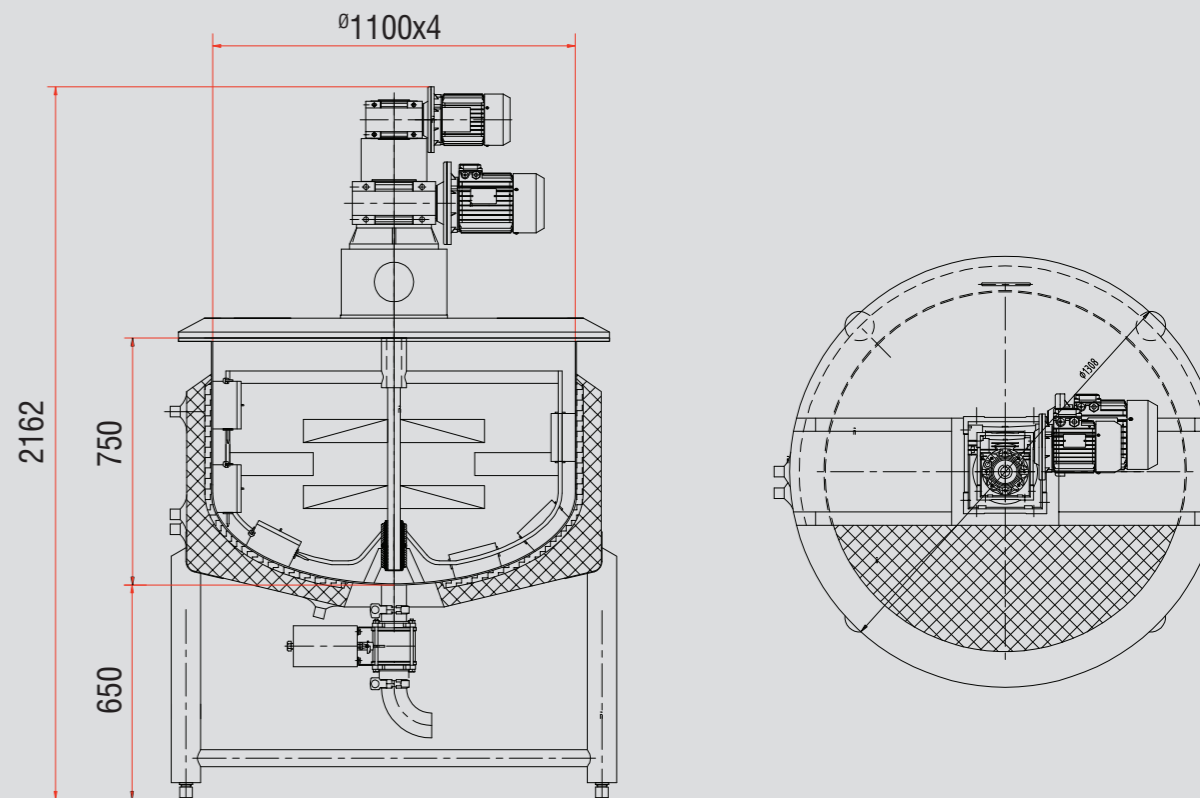

PPN MACHINERY
PROPRIETARY
LIMITED
THE COMPLETE PACKAGE

PROCESSING & PACKAGING EQUIPMENT CUSTOM DESIGN SERVICES
For more information on this machines call sales: +61 3 9791 7011 or any others visit: www.iopak.com