

# Paddle Mixer MIX-1500

Total capacity [L]	1500
Max filling [L]	1200
Installed Power [kW]	16
Loader option	PZ-2/250
Column Loader power [kW]	0,75
Standard control	button control panel
Shaft rotation speed [rpm]	14/28 II rotation speed & left/right rotation
Mixer net weight [kg]	1950
Unloading to bin DIN 9797	200 l
Opennig/closing lids	pneumatically

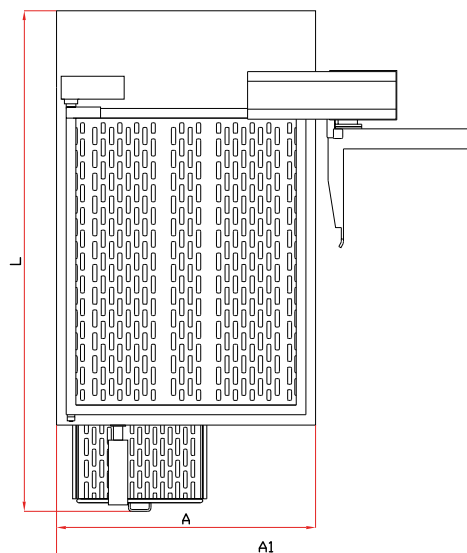
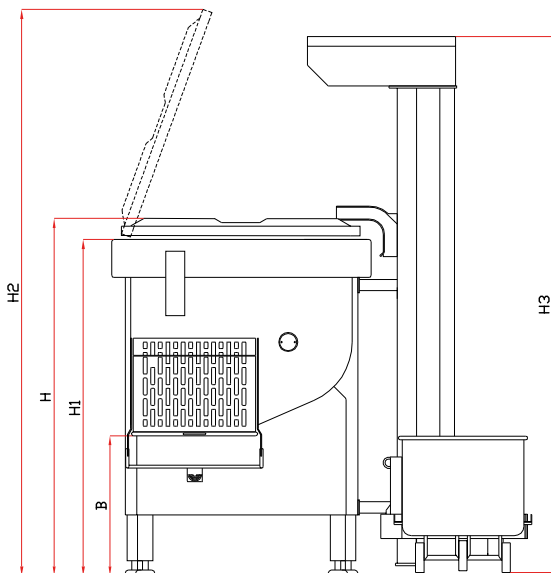

L [cm]	A [cm]	A1 [cm]	H [cm]	H1 [cm]	H2 [cm]	H3 [cm]	B [cm]
264	137	225	189	177	300	282	72±2