

## iopak ahead of the pack

This new IOPAK stand alone piston filler is fitted with a rotary valve and is suitable for sauces, yogurt, pastes as well as viscous creams.

### FEATURES

- Rotary valve on fill head
- Positive shut-off nozzle (eliminating dripping)
- Stroke limitation fill volume adjustment.
- It is designed as a stand alone filling station or as part of an in-line configuration.
- It is fitted with a removable infeed hopper
- Stainless steel construction.
- The filling cycle is initiated by a foot operated pedal or it can be used in-line.
- Control system is electro / pneumatic.
- Dimensions: 1,700 x 700 x 1,800 mm (l x w x h)
- Nozzle diameter 10mm

## ROTARY VALVE PISTON FILLER WITH HOPPER 5000L

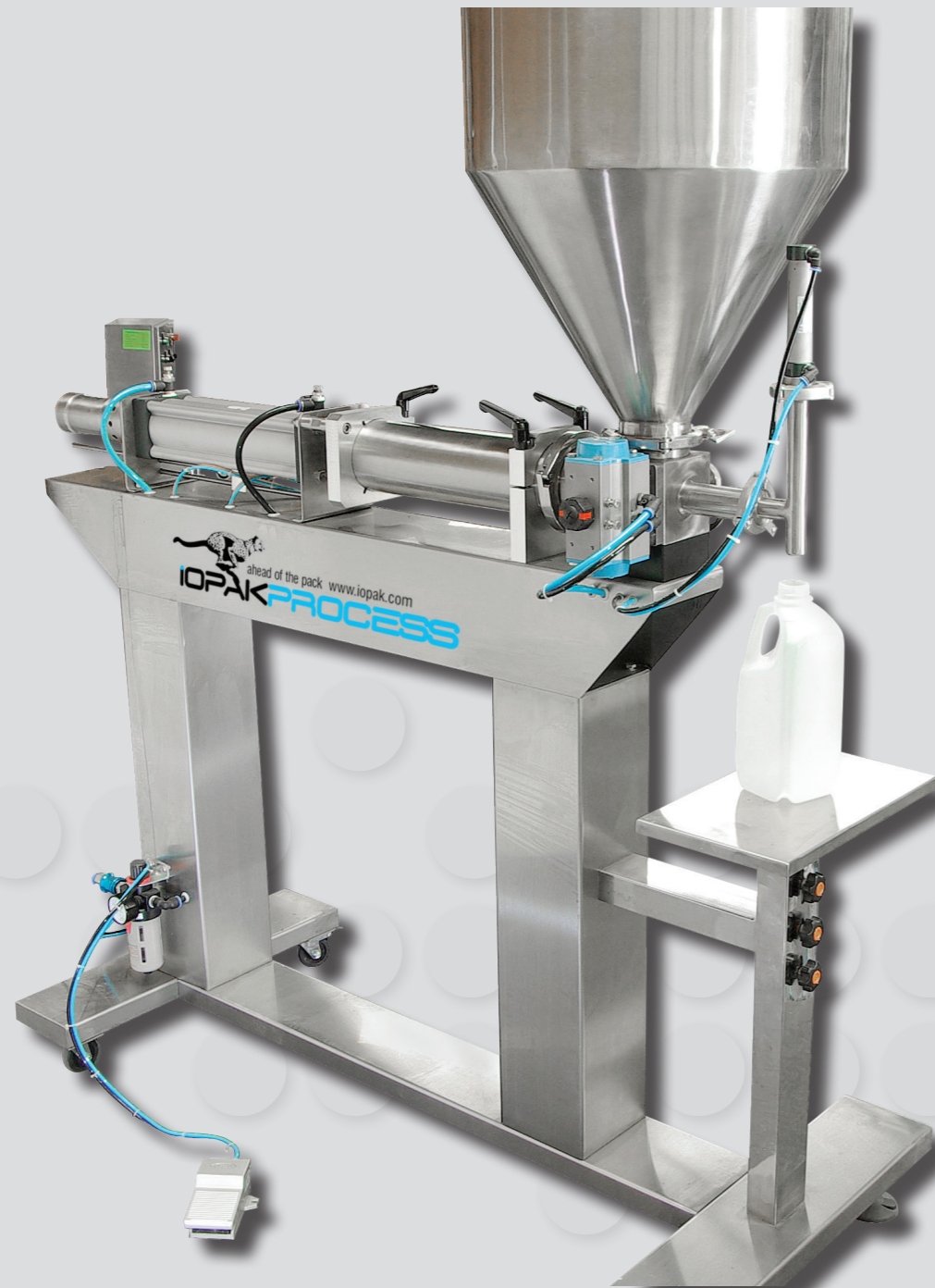

**PPN** MACHINERY PROPRIETARY LIMITED  
THE COMPLETE PACKAGE

## ROTARY VALVE PISTON FILLER WITH HOPPER

STOCK ITEM: 7395

### Specifications

- Filling Range: 500 - 5,000ml (5 litres)
- Accuracy: + -1%.
- Air Supply Requirement: 3.5 Kg/cm<sup>2</sup> (50 PSI or 350 KPa)
- Air Consumption: 5.7ft<sup>3</sup>/min
- Electric Supply: 240V AC single phase).

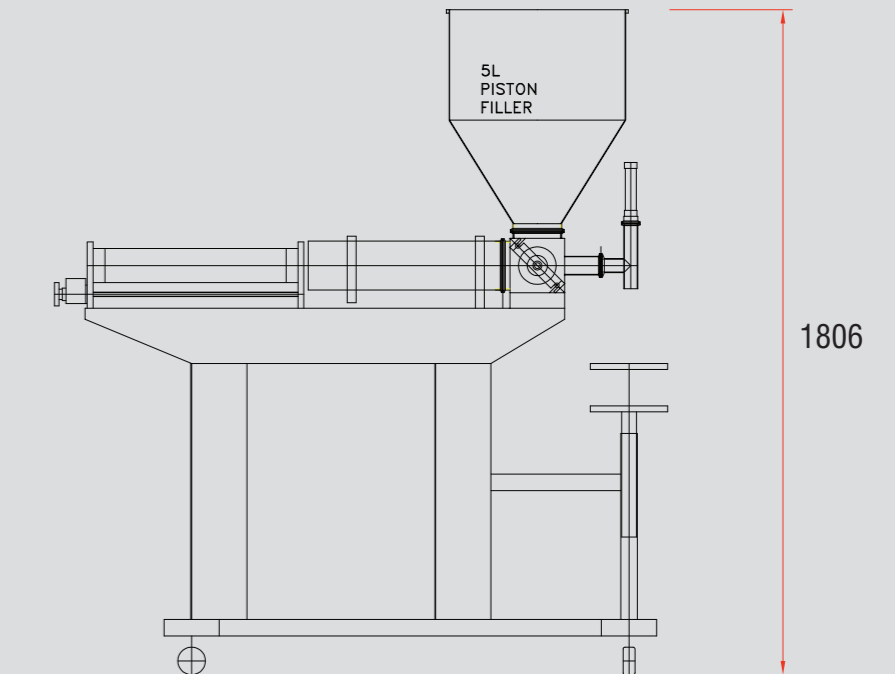
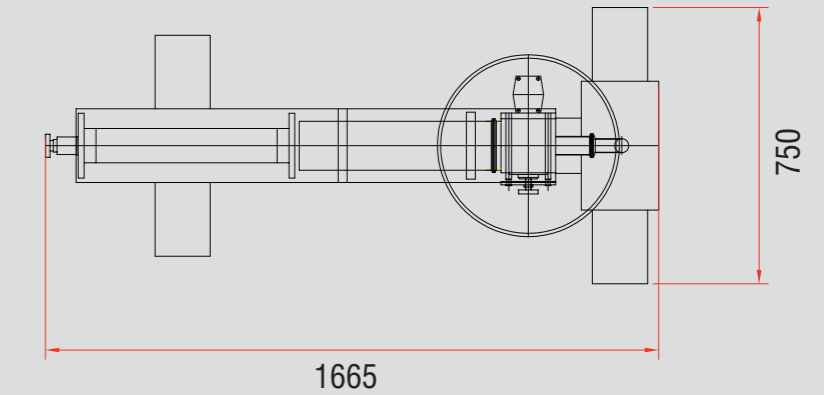

NEW & INNOVATIVE PRODUCTS



NEW & INNOVATIVE PRODUCTS



**PPN** MACHINERY PROPRIETARY LIMITED  
THE COMPLETE PACKAGE

PROCESSING & PACKAGING EQUIPMENT CUSTOM DESIGN SERVICES  
For more information on this machines call sales: +61 3 9791 7011 or any others visit: [www.iopak.com](http://www.iopak.com)