

Brand new machine at excellent price!

- Infeed and outfeed rollers. Normally an optional extra for carton tapers.
- Mounted on lockable castors. Mobility when you need it, stability when you don't.
- Box height indicator. Clearly marked in centimetre/half-cm divisions. Makes adjustment a breeze.
- Driven by 2 powerful 120W motors mounted beneath the conveyor. Better grip and torque for heavier boxes.
- Carton guides. Position the box for precise tape application.
- Tapes both the top and bottom of the box
- Includes tool set.

SIDE DRIVE CARTON TAPER S/S: SD5050

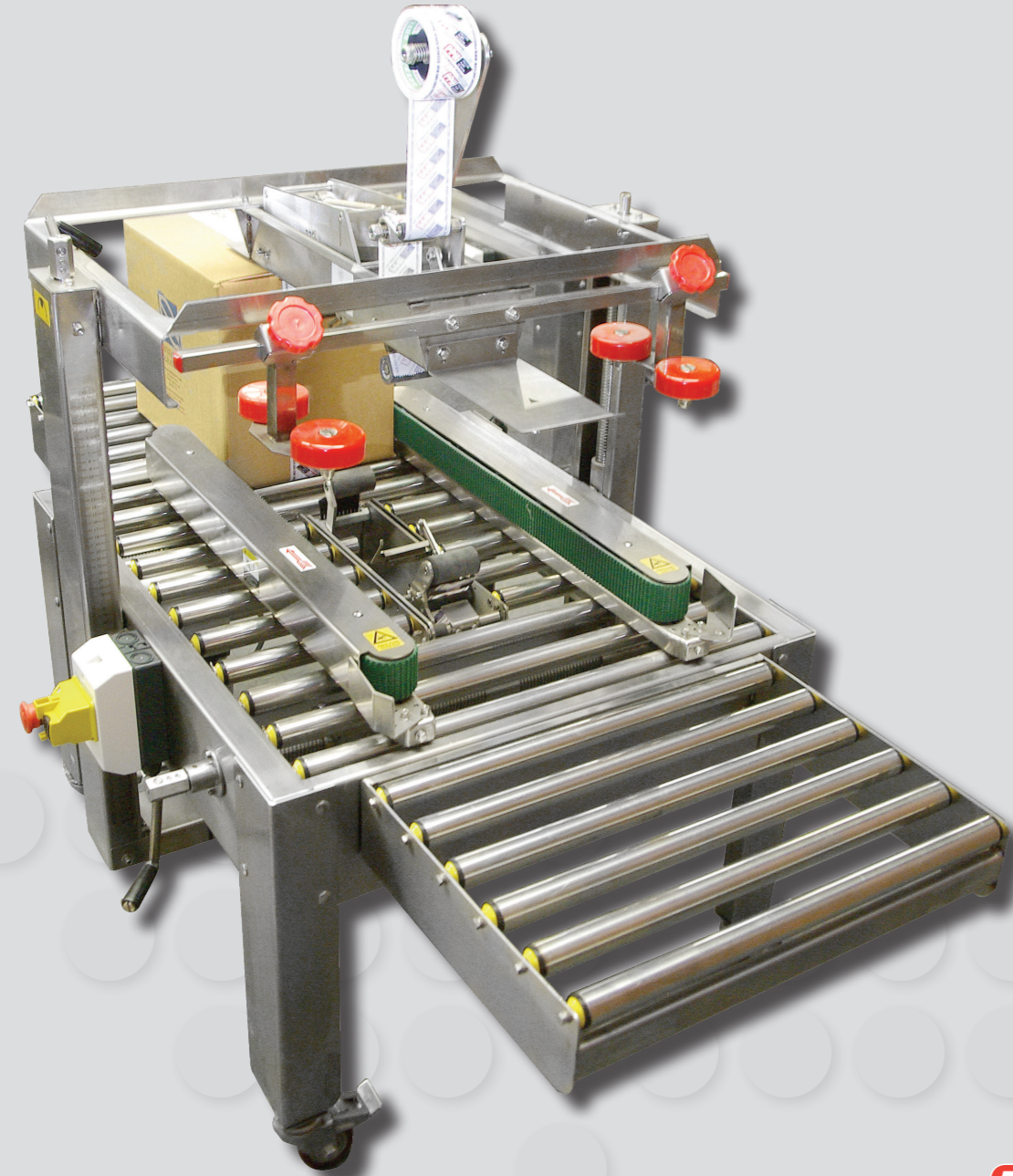

NEW & INNOVATIVE PRODUCTS



PPN MACHINERY PROPRIETARY LIMITED
THE COMPLETE PACKAGE

S/S SIDE DRIVE CARTON 5050 S/S TAPER

STOCK ITEM: 17721

Specifications

- Stainless steel rollers
- Non-corrosive plastic bearings
- Sturdy Stainless Steel Body construction.
- 2 x 240 V 50Hz 1400 RPM 120 W electric motors via 17:1, 60 Nm Reducer to achieve a belt speed of 16.3 m/min.
- Power 240V/50Hz 120W
- Sealing Capacity Up to 20 Cartons/minute (Standard Box)
- Minimum Sealing Size - 100mm W x 120mm H
- Maximum Sealing Size - 500mm W x 500mm H
- Adhesive Band Used - BOPP Brown Paper, PV Adhesive Band
- Width of Adhesive Band - Up to 60mm
- Height of Working Table - 550mm-760mm Adjustable
- Dimensions (including infeed/outfeed rollers) 1660mm L x 740mm W x 1300mm H
- Net Weight - 120kg

NEW & INNOVATIVE PRODUCTS



PPN MACHINERY PROPRIETARY LIMITED
THE COMPLETE PACKAGE

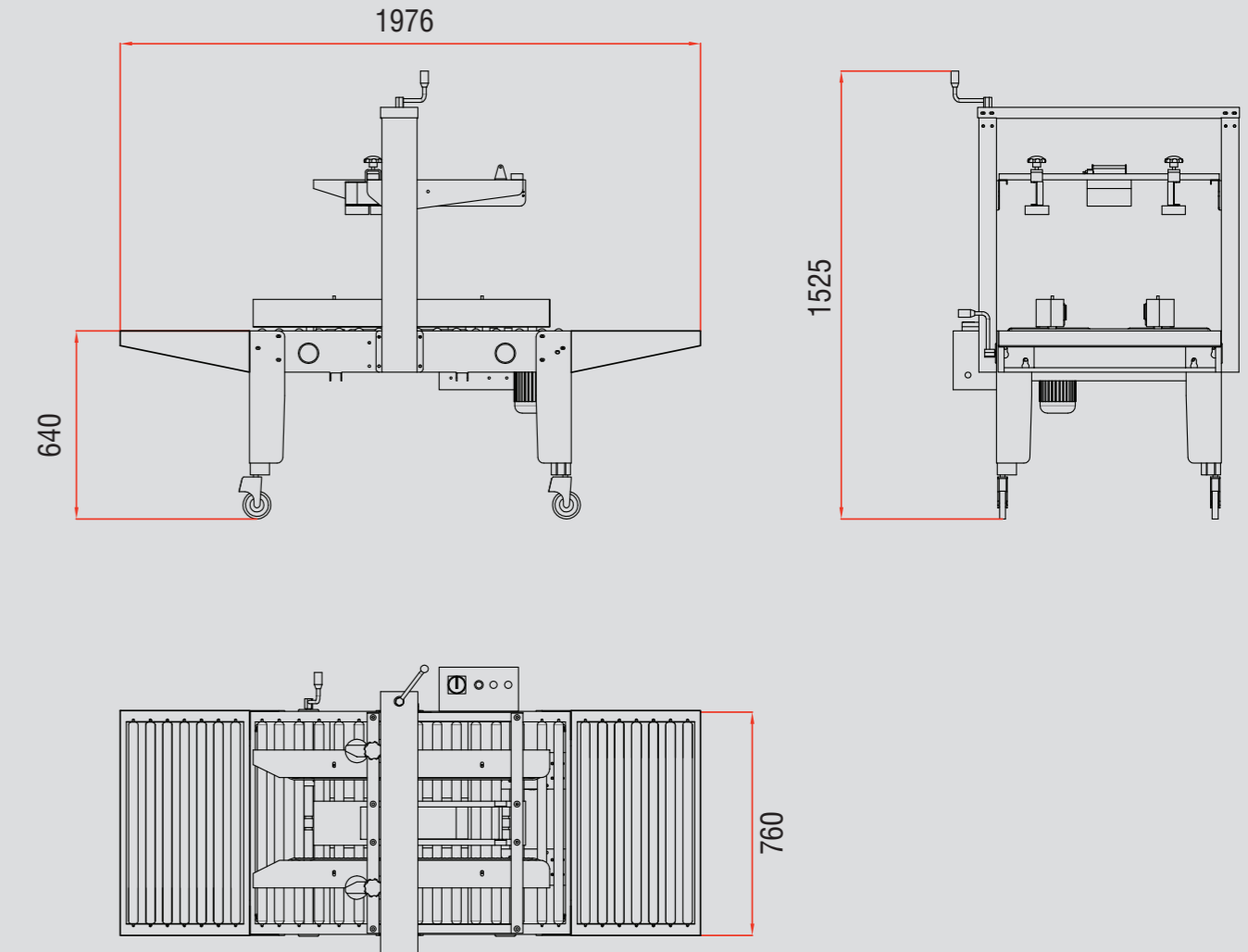

PROCESSING & PACKAGING EQUIPMENT CUSTOM DESIGN SERVICES
For more information on this machines call sales: +61 3 9791 7011 or any others visit: www.iopak.com