

Designed for micro molecules or powder, (applications vary widely in the food industry) for products such as milk powder, glucose powder, albumen, coffee, rice powder and seasonings etc.

SERVO DRIVEN AUGER FILLER: SAF-350



SERVO DRIVEN AUGER FILLER: SAF-350

STOCK ITEM: 16571G

Specifications

- Fill Range: Max 1,000 gms
- Accuracy: +/- 0.3 – 1 %
- (Product & Fill Volume Dependent)
- Speed: Product Dependent
- Hopper Size: 25 L
- Material Constructions: SUS304
- Touch Screen: 5.7" EVIEW
- PLC: PANASONIC
- Servo Motor: PANASONIC
- Level Sensor: Tuning Fork
- Lower Voltage Electrics: SCHNEIDER

Options

- Positive Shut-Off Nozzle
- Spinner Lower Voltage Electrics:

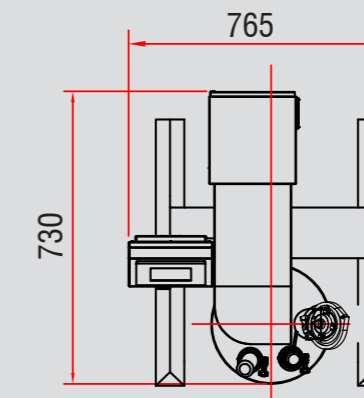
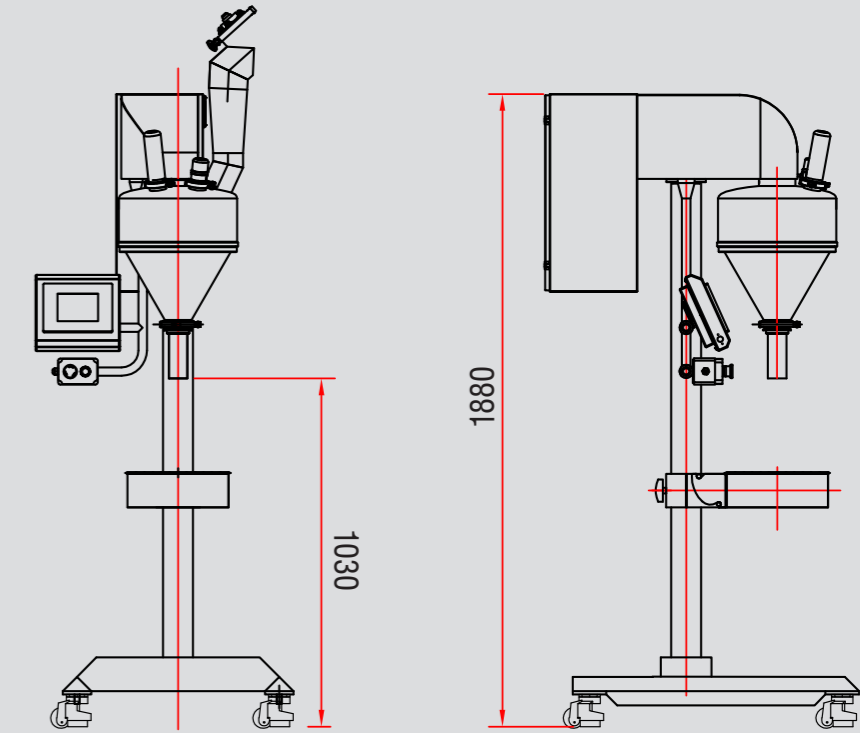

NEW & INNOVATIVE PRODUCTS



NEW & INNOVATIVE PRODUCTS

