

## iopak ahead of the pack

This brand new s/s IOPAK “cleanskin” storage tank with a conical bottom is ideal for viscous products like Mayonaise, Yoghurt & Honey.

### Features

- Conical Bottom
- Forkliftable
- Storage with lid
- Add wheels for mobile container
- Sturdy braced legs
- Very versatile (mix, store, move)
- Butterfly valve included
- VERY COMPETITIVELY PRICED

## 2500L FORKLIFTABLE STORAGE TANK (CONICAL BOTTOM)



**PPN** MACHINERY PROPRIETARY LIMITED  
THE COMPLETE PACKAGE

## 2500L FORKLIFTABLE STORAGE TANK (CONICAL BOTTOM)

STOCK ITEM: 16543

### Specifications

- Total Volume: 2,500 Ltr
- Material Construction: SUS304
- Outlet: 4” Butterfly Valve
- Included Accessories:
- 38mm CIP
- 2” Inlet
- Manhole

NEW & INNOVATIVE PRODUCTS  
**iopak**  
ahead of the pack

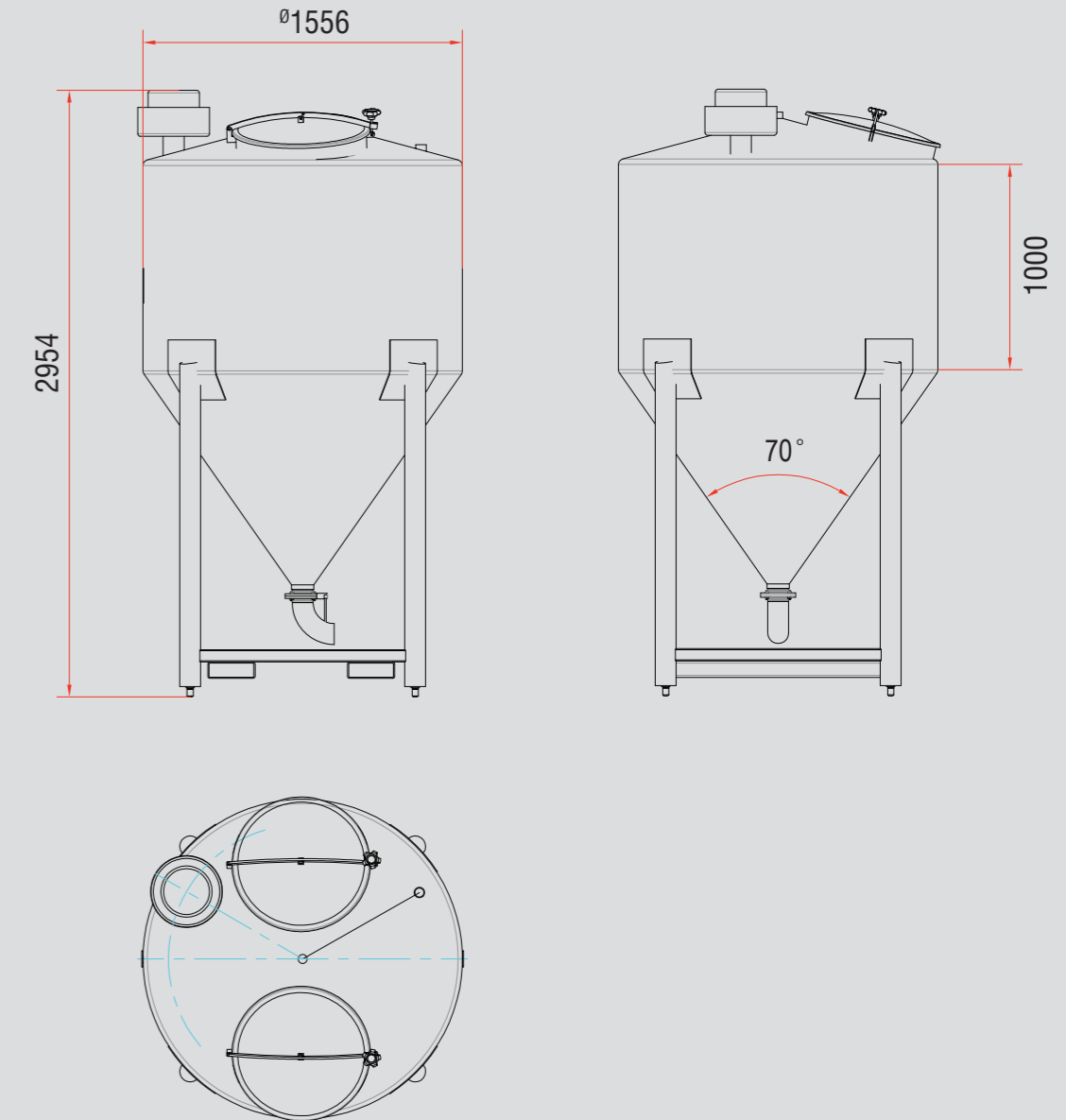

**PPN** MACHINERY PROPRIETARY LIMITED  
THE COMPLETE PACKAGE

PROCESSING & PACKAGING EQUIPMENT CUSTOM DESIGN SERVICES  
For more information on this machines call sales: +61 3 9791 7011 or any others visit: [www.iopak.com](http://www.iopak.com)