

## iopak ahead of the pack

This brand new IOPAK Slat Belt conveyor is fitted with a modular plastic "Intralox" type belt and is widely used in the BOTTLING or PACKAGING industries. Because of the low friction of Slat Conveyors they are also used in the labelling industry.

An IOPAK rotary accumulating table could be used to feed bottles, containers or cans onto the conveyor, where a sensor can be fitted to position the containers for precise filling.

## SANITARY QUICK RELEASE CONVEYOR



## SANITARY QUICK RELEASE CONVEYOR

STOCK ITEM: 16452

### Specifications

- Belt Type: Flat Belt, Food Grade - Polyurethane with 2 x tracking strips
- Construction: Full stainless steel construction
- Dimensions of belt: 2.2m long x 200mm wide belt x 850mm working height
- Drive: SEW Motor and gearbox, 0.25kW, 29 RPM
- Variable Speed Controller: SEW Integral Unit
- Bearing Type: Stainless Steel with quick release mechanism
- Other: Working Table with adjustable height.
- Working table also has adjustable horizontal back stop.
- Conveyor end has removable end stop
- Cross stop plate on infeed is adjustable up and down, in and out and telescopic in length
- Conveyor on castors (SS, swiveable and lockable)

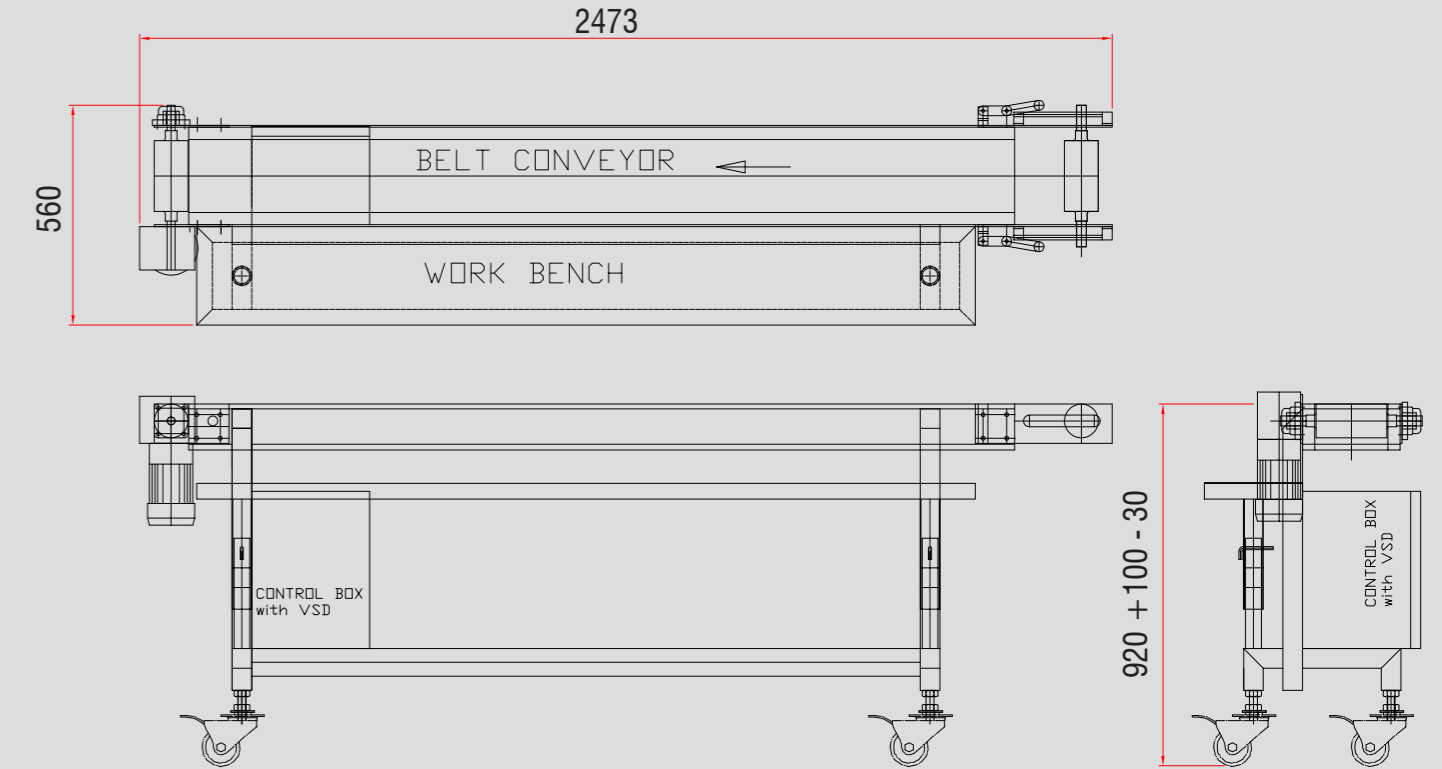

NEW & INNOVATIVE PRODUCTS



NEW & INNOVATIVE PRODUCTS

