

CREAM CHILLER

Capacity 1,000L/Hr
 Tank Capacity: 300L
 Product Contact: SUS316
 (SUS304 for Non-Contact)
 Cream Inlet Temperature 36 Â°C
 Flow Temperature 36Â°C- 4 Â°C
 It is equipped with 1.5" Rotary Lobe Pump (1,000L/hr) -
 This cream cooler will be supplied to Australian Standards.
 It will be skid mounted.



NEW & INNOVATIVE PRODUCTS



CREAM CHILLER

STOCK ITEM: 14621

Specifications

- Capacity 1,000L/Hr
- Tank Capacity: 300L
- Product Contact: SUS316 (SUS304 for Non-Contact)
- Cream Inlet Temperature 36 Â°C
- Flow Temperature 36Â°C- 4 Â°C
- It is equipped with 1.5" Rotary Lobe Pump (1,000L/hr) -
- This cream cooler will be supplied to Australian Standards. It will be skid mounted.

NEW & INNOVATIVE PRODUCTS

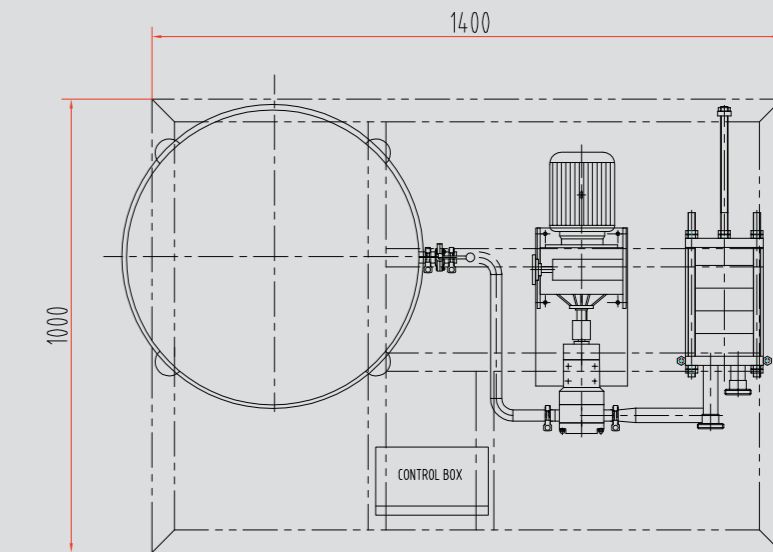
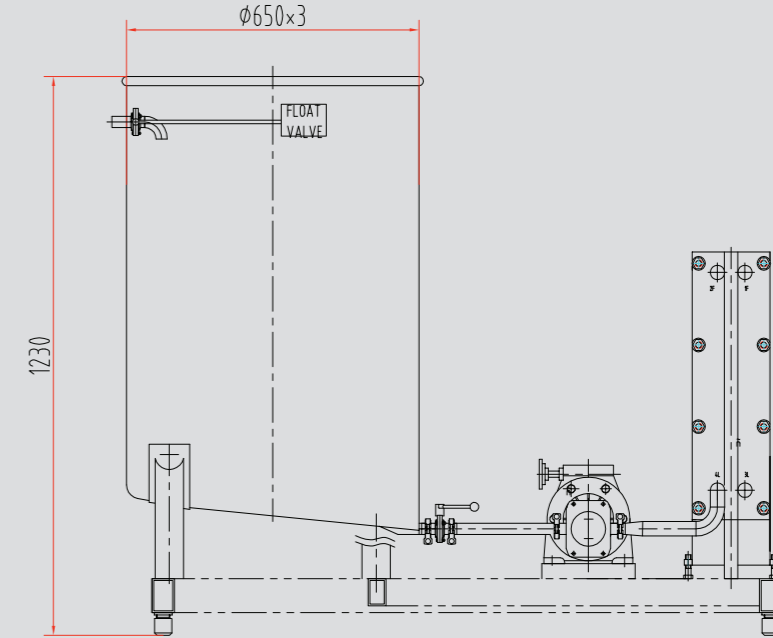

PROCESSING & PACKAGING EQUIPMENT CUSTOM DESIGN SERVICES
 For more information on this machines call sales: +61 3 9791 7011 or any others visit: www.iopak.com