

iopak ahead of the pack

This 250L pre-mix or mixing tank has proved a runaway winner with many food manufacturers.

The tank is supplied with a high shear mixer / disperser fitted with a general purpose slotted screen.

HIGH SHEAR BATCH MIXER + 250L TANK



HIGH SHEAR BATCH MIXER + 250L TANK

STOCK ITEM: 14568G

- Working Capacity : 200~800L at 2800 RPM(product dependant)
- Motor Size : 7.5kW
- Shaft Length : 650mm
- Shaft Diameter : 235mm
- Product Discharge: Bottom Outlet
- Outlet Diameter: 51mm
- Outlet Height : 358mm
- Overall Height: 1,849mm
- SS Safety Grid (no safety interlocks)
- Half moon lid

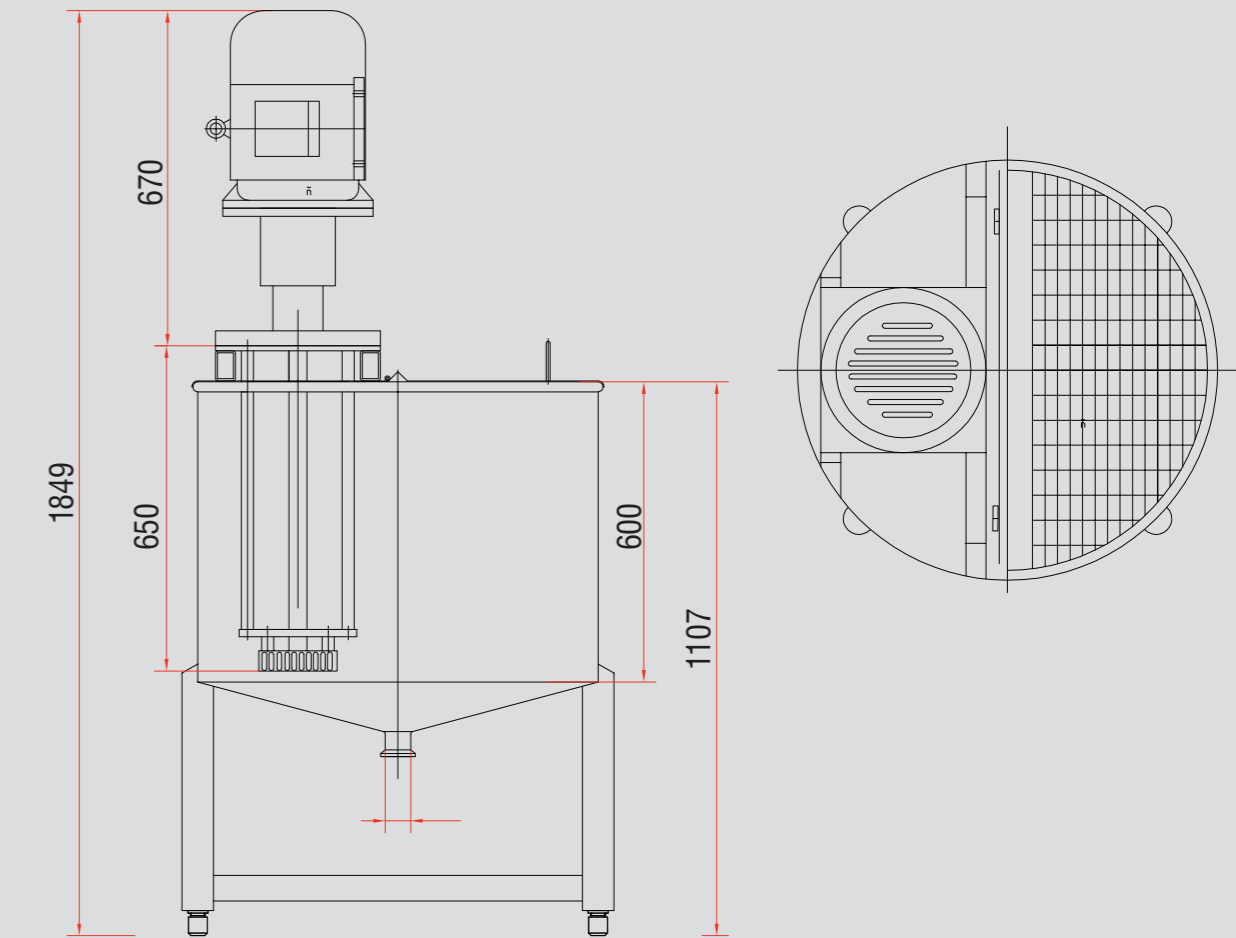

NEW & INNOVATIVE PRODUCTS



NEW & INNOVATIVE PRODUCTS

