

The IOPAK In-Line Powder / Liquid Mixing Dispensing System, consists of the following equipment.

- Emulsion Pump TRL1-165-7.5 (2,900 rpm)
- Self Priming Pump ZXB-SY20-4 (1,450 rpm)
- Working Table
- Powder Hopper/Funnel
- Electrical Control Box

## IN-LINE POWDER / LIQUID MIXING DISPERSING SYSTEM



## IN-LINE POWDER / LIQUID MIXING DISPERSING SYSTEM

STOCK ITEM: 14555G

### Specifications

- Flow Capacity: 3t/hr (Product Dependent)
- Motor Size: 7.5kW
- In/Outlet Diameter: 51 mm
- Hopper Outlet Diameter: 76 mm
- (Hopper Outlet Equipped with Ball Valve)
- 3-Way Ball Valve for CIP Purpose
- Working Height: 1,020 mm

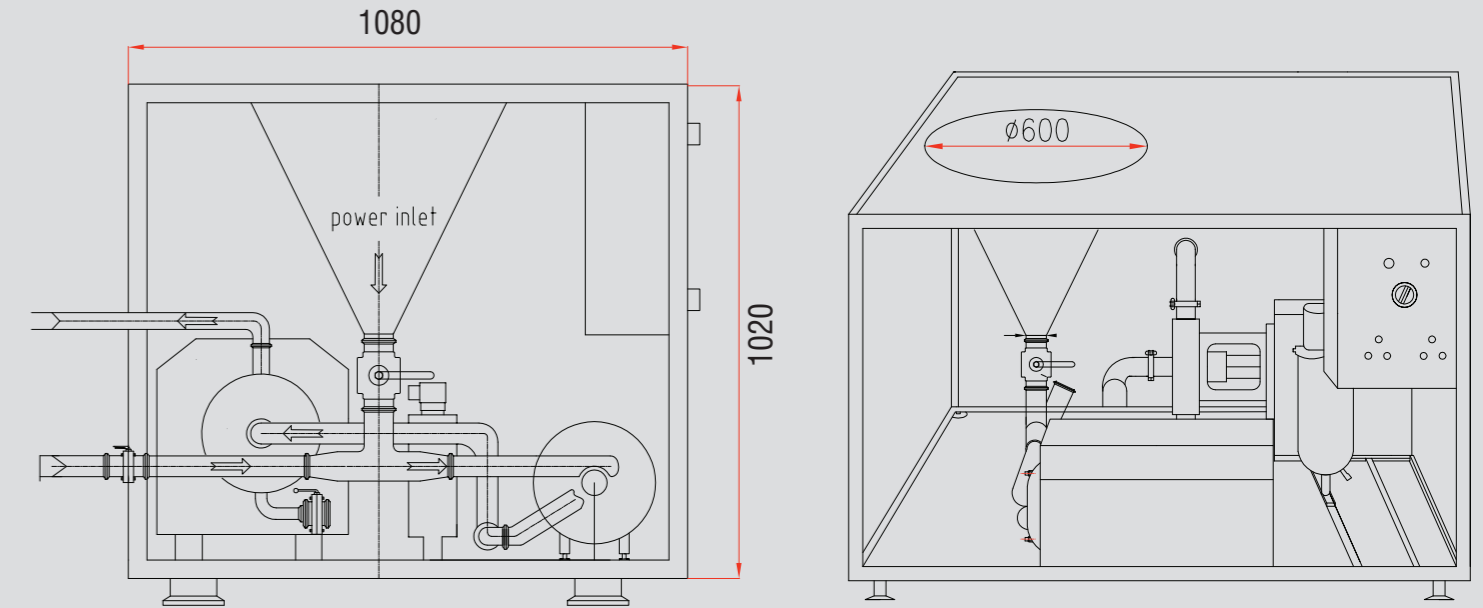

PROCESSING & PACKAGING EQUIPMENT CUSTOM DESIGN SERVICES  
For more information on this machines call sales: +61 3 9791 7011 or any others visit: [www.iopak.com](http://www.iopak.com)