

iopak ahead of the pack

This BRAND NEW rotary lobe 3" (75mm) hot water jacketed pump comes with an ABB motor, water proof control box, white wheel S/S castors, Trolley with handle, BSM connectors, S/S Cover, Mechanical seal. The pump is of excellent quality and very keenly priced.

3" ROTARY LOBE PUMP WITH CONTROL BOX MODEL ZB3A-100



3" ROTARY LOBE PUMP WITH CONTROL BOX MODEL ZB3A-100

STOCK ITEM: 14466G

Specifications

- Contact material SUS316
- [Lobe Pump]
- Flow: 6000 - 18,000 litres / hr. (nominal - subject to product and head)
- Pressure: 5 Bar
- Power: 5.5kW
- Speed: 450RPM
- Stainless Steel rotors

ABB Motor - IEC34-1

- Size: 5.5kW
- Voltage: 415V
- Amp: 12.1A
- Frequency: 50Hz
- Other: IP55 Rated, 52.5Nm

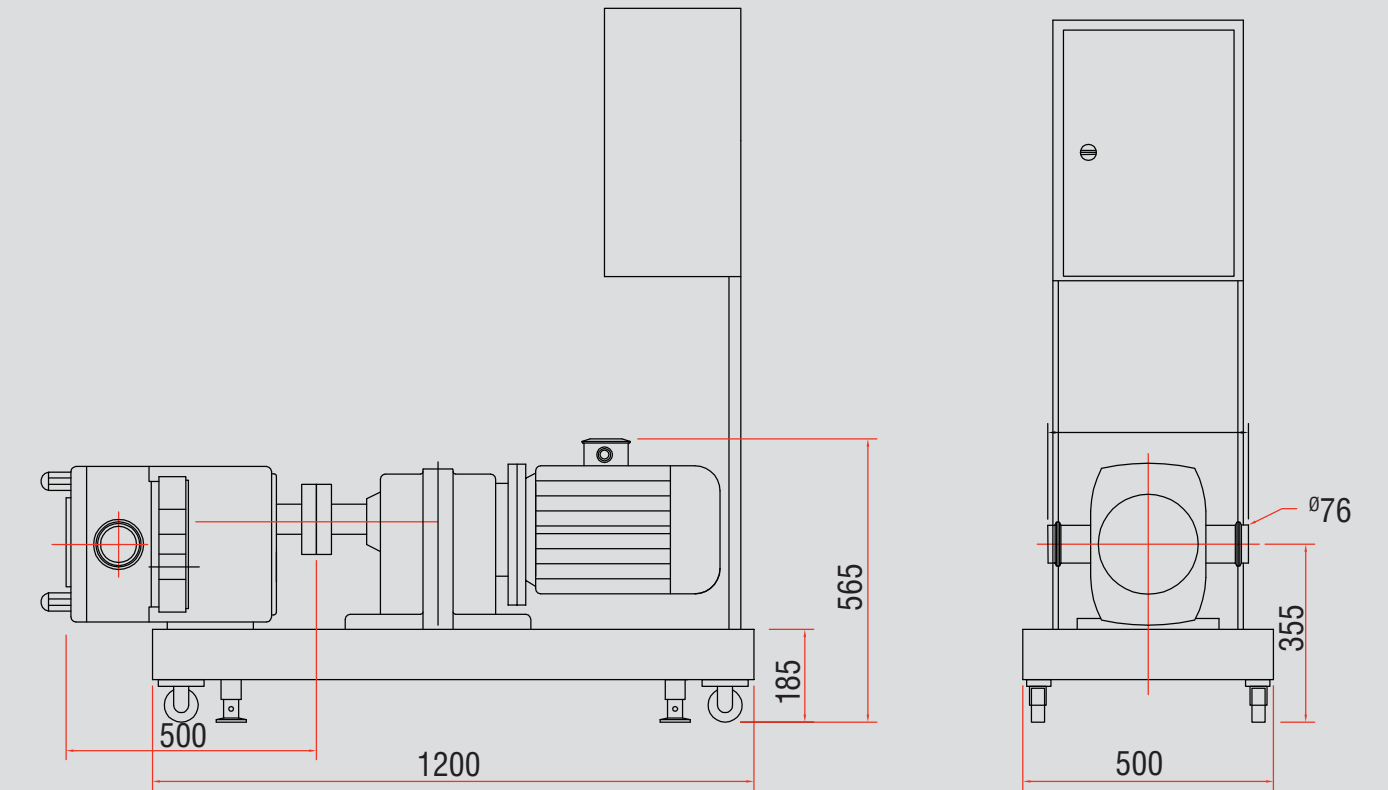

NEW & INNOVATIVE PRODUCTS



NEW & INNOVATIVE PRODUCTS

