

iopak ahead of the pack

This is a BRAND NEW IOPAK stainless steel inclined auger. It is very useful for conveying powders or granules. It has a 100mm dia auger with 70mm pitch flights.

The infeed hopper has mouth dimensions of 690 x 890mm and is set at 1000mm above floor level. The discharge is set at 2700mm above floor level.

The screw is driven by a 415V AC, Three Phase, 1400mm (Input) TEFC, Gear Motor which is direct coupled to the screw.

An 0.35KW eccentric vibrator is fitted to the hopper wall to assist feed. Construction is of Stainless Steel and the unit is mounted on wheels and lockable castors.

NEW & INNOVATIVE PRODUCTS



INCLINED AUGER SCREW CONVEYOR WITH ROUND HOPPER: GS-S3/2700



PPN MACHINERY PROPRIETARY LIMITED
THE COMPLETE PACKAGE

INCLINED AUGER SCREW CONVEYOR WITH ROUND HOPPER GS-S3/2700

STOCK ITEM: 14401G

Specifications

- Lift Capacity: 3 - 5³m /h
- Hopper Size: 200L
- Conveyor Height: 2,700mm
- Power Supply: 380V, 50Hz, 3 phase, 5 pin, 10 Amps, neutral
- Recommended Oil: TORA 220 or equivalent (if the gearbox is 7 years old or more, TORA 320 or equivalent)

NEW & INNOVATIVE PRODUCTS

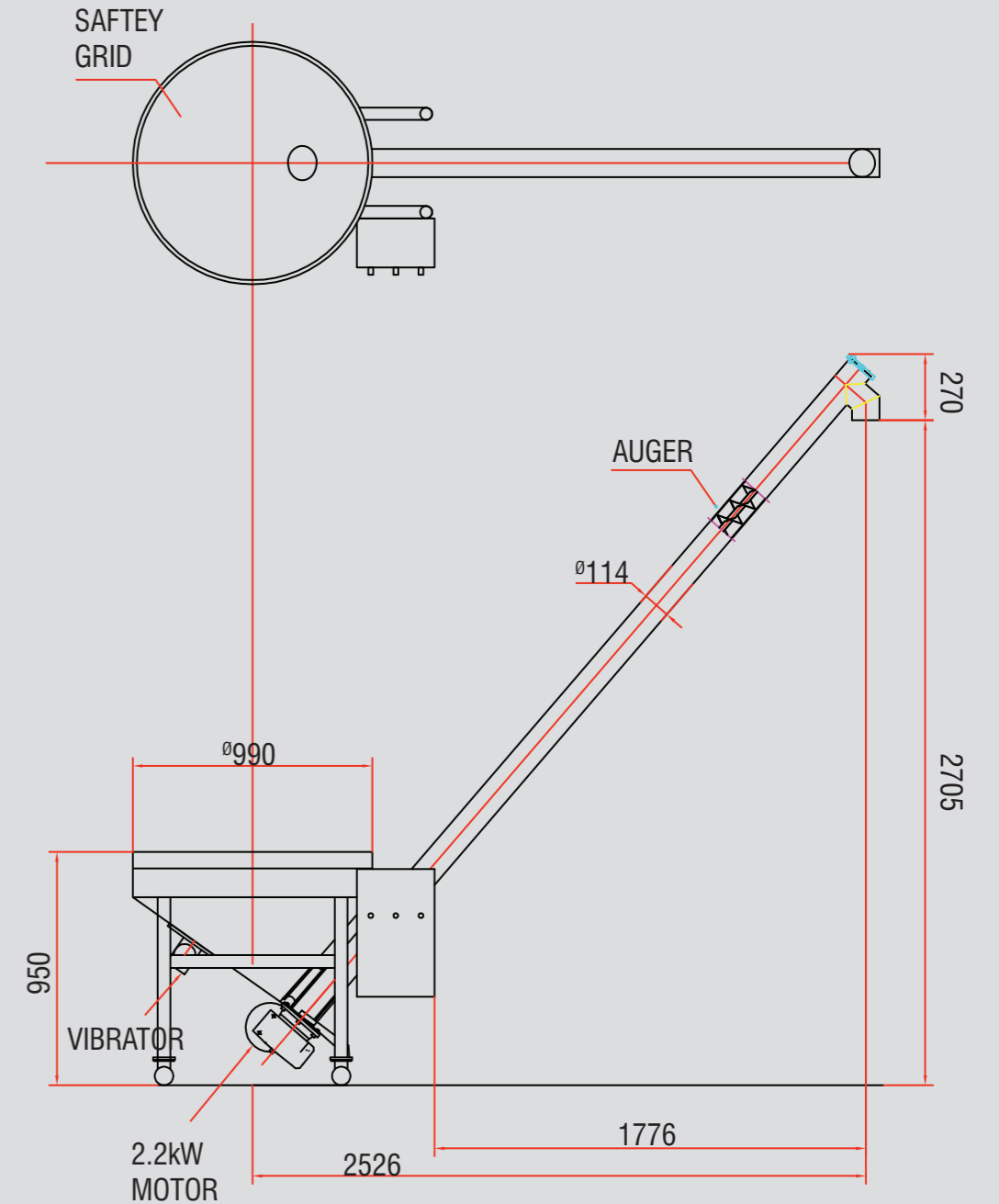

PPN MACHINERY PROPRIETARY LIMITED
THE COMPLETE PACKAGE

PROCESSING & PACKAGING EQUIPMENT CUSTOM DESIGN SERVICES
For more information on this machines call sales: +61 3 9791 7011 or any others visit: www.iopak.com