

iopak ahead of the pack

JUST THE RIGHT TORQUE FOR ALL YOU HONEY,OIL SAUCE, SOUP & COSMETIC MANUFACTURERS - THIS GREAT LITTLE CAPPER IS FOR YOU!

You have to cap immediately after filling - correct? The bottleneck caused by hand capping can result in contamination and spoilage - and then you have the added burden of leaking containers.

Let the IOPAK Pneucap CT-2 Semi -Automatic Capper solve all your capping problems. It can handle Plastic Screw Caps, Snap Hinge Caps and Cap and Flex Band Caps for general products  
Capping Speed: 15 bottles/min.

## SEMI-AUTOMATIC PNEUMATIC CAPPER: PNEUCAP CT-2

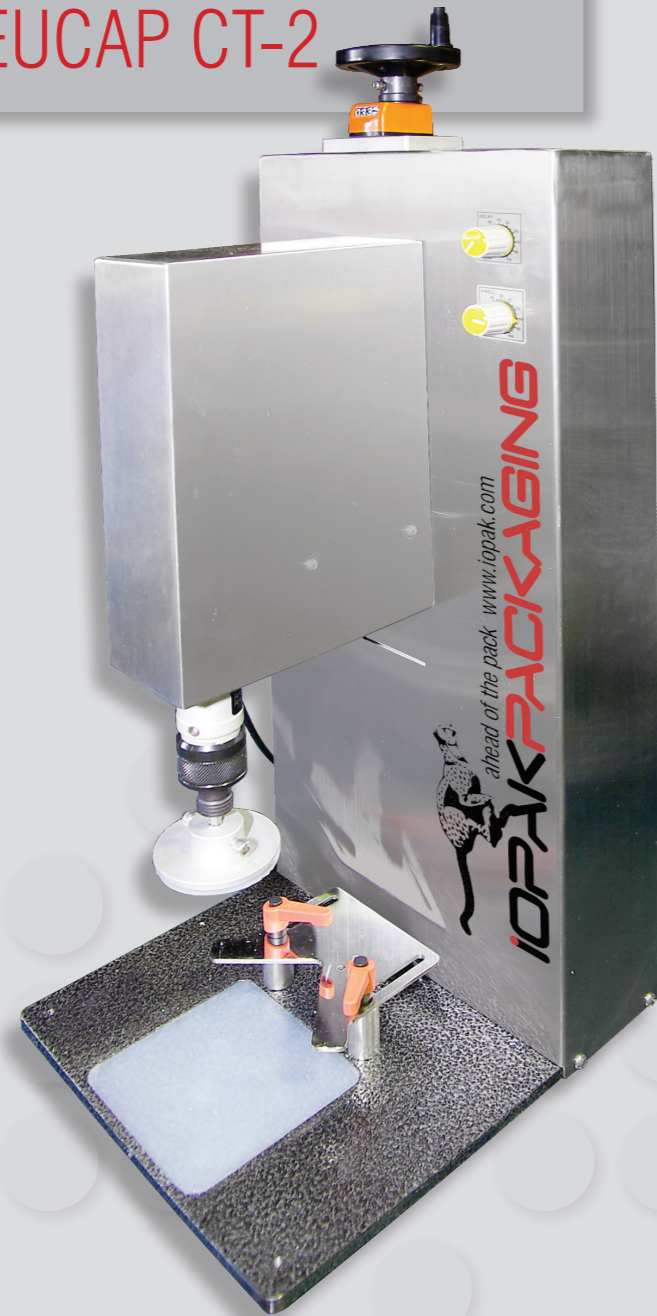

NEW & INNOVATIVE PRODUCTS



**PPN** MACHINERY PROPRIETARY LIMITED  
THE COMPLETE PACKAGE

## SEMI-AUTOMATIC PNEUMATIC CAPPER PNEUCAP CT-2

STOCK ITEM: 14139

### Specifications

- Speed: 15 bottles/min (Product Dependent)
- Cap Size: 20 - 110mm Diameter
- Bottle Height: Max 200 mm
- Power Supply: 110/220VAC, 50Hz
- Machine size: 250 L x 280 W x 500 H mm
- Weight: 12 Kg

\* IOPAK Pneucap CT-2 can be designed to handle 24 different torque combinations.

NEW & INNOVATIVE PRODUCTS



**PPN** MACHINERY PROPRIETARY LIMITED  
THE COMPLETE PACKAGE

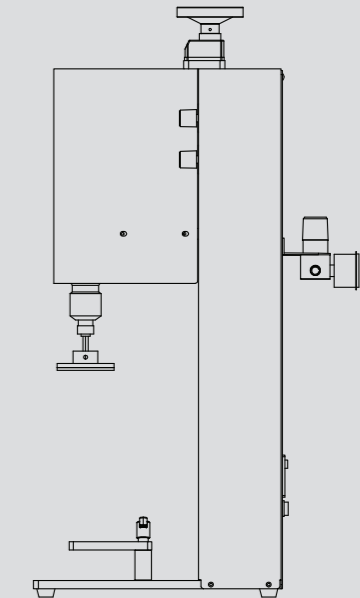
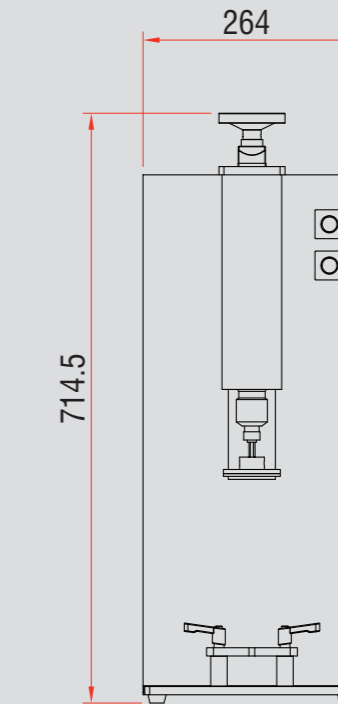
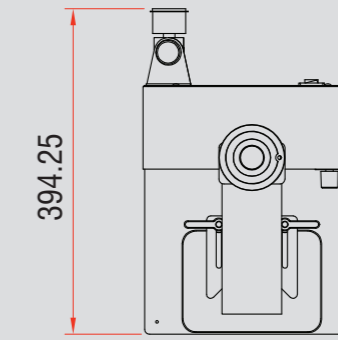

PROCESSING & PACKAGING EQUIPMENT CUSTOM DESIGN SERVICES  
For more information on this machines call sales: +61 3 9791 7011 or any others visit: [www.iopak.com](http://www.iopak.com)