

iopak ahead of the pack

This brand new fully stainless steel constructed blender is designed for the food or chemical industry. This specific unit was designed for a moist food paste.

NOTE: IF YOU WANT A LARGER OR SMALLER SIZE - JUST CALL OR EMAIL US. WE MAKE THE SIZE YOU REQUIRE IF POSSIBLE.

S/S RIBBON BLENDER 5000L: MIX 5000



S/S RIBBON BLENDER 5000L MIX 5000

STOCK ITEM: 14010G

Specifications

- Double ribbon (contra flow) configuration
 - Outrigger bearing/stuffing box seal arrangements at both shaft endings,
 - 150mm dia pneumatically operated butterfly valve discharge,
 - 150mm dia dust extraction port and substantial bar mesh guarding under a hitch up hinged lid arrangement.
 - Working dimensions 2450 x 800 x 1150mm
 - A 415V AC, Three Phase 30 kW, 18 (Output) RPM Gear motor (Worm wheel & Pinion) is direct coupled to the blender shaft.
 - Recommended Oil: TORA 220 or equivalent (if the gearbox is 7 years old or more, TORA 320 or equivalent)
- * Please note the price excludes electrical and safety work.

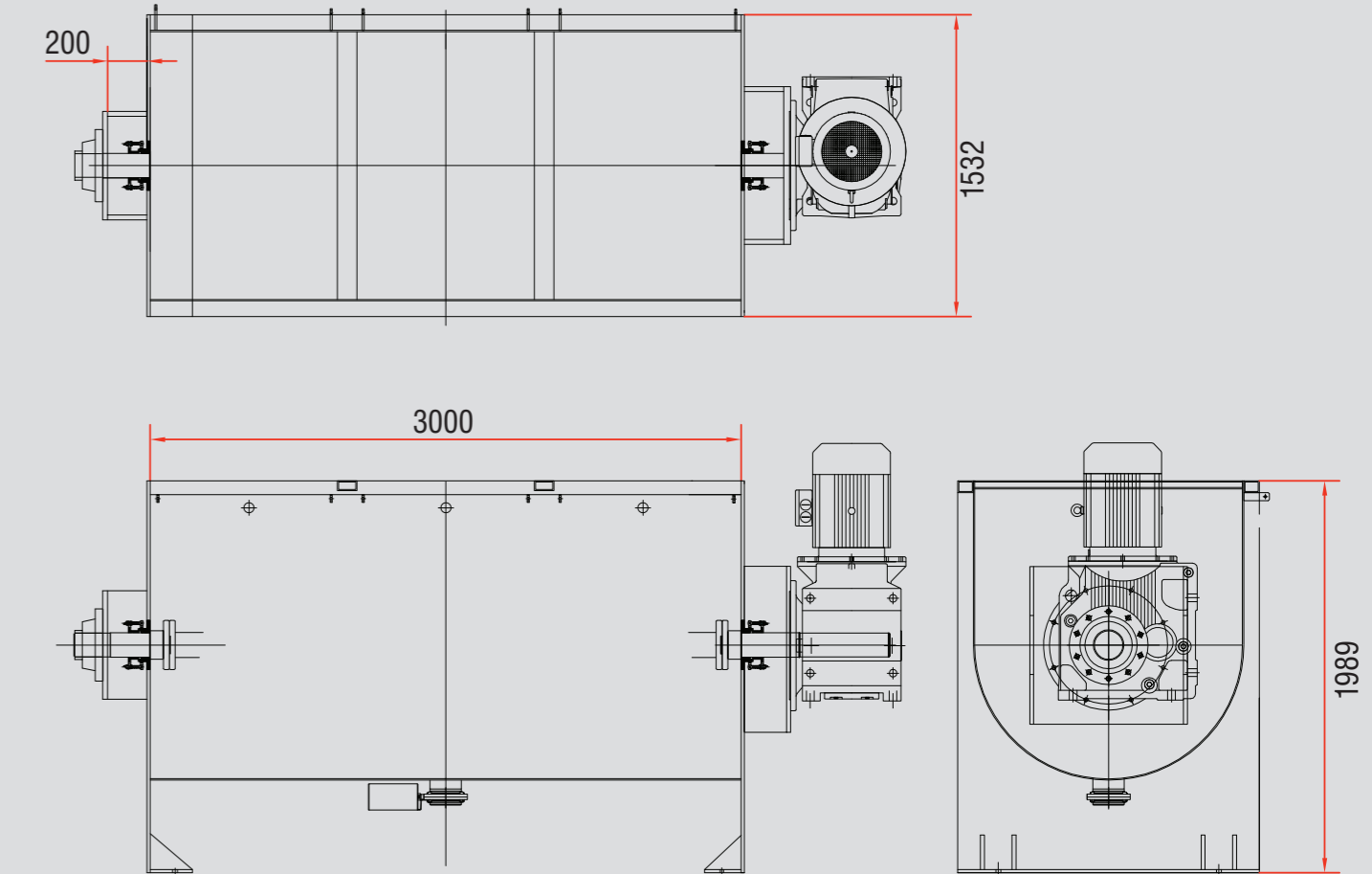

NEW & INNOVATIVE PRODUCTS



NEW & INNOVATIVE PRODUCTS

